

BULK SOLIDS HANDLING EQUIPMENT

SILO VENTING FILTERS

R03 SILO VENTING FILTERS

R03 is a cylindrically shaped dust collector for venting of pneumatically filled silos. The stainless steel body contains vertically mounted, filter elements. The air jet cleaning system is integrated in the hinged weather protection cover.

Silo Venting Filters

R03

Performance & Technical Features - Benefits

- Valve body : AISI304
- Temperature: -20°C ~ +80°C
- Medium: 40um compressed air, dry and dew point to -20 °C

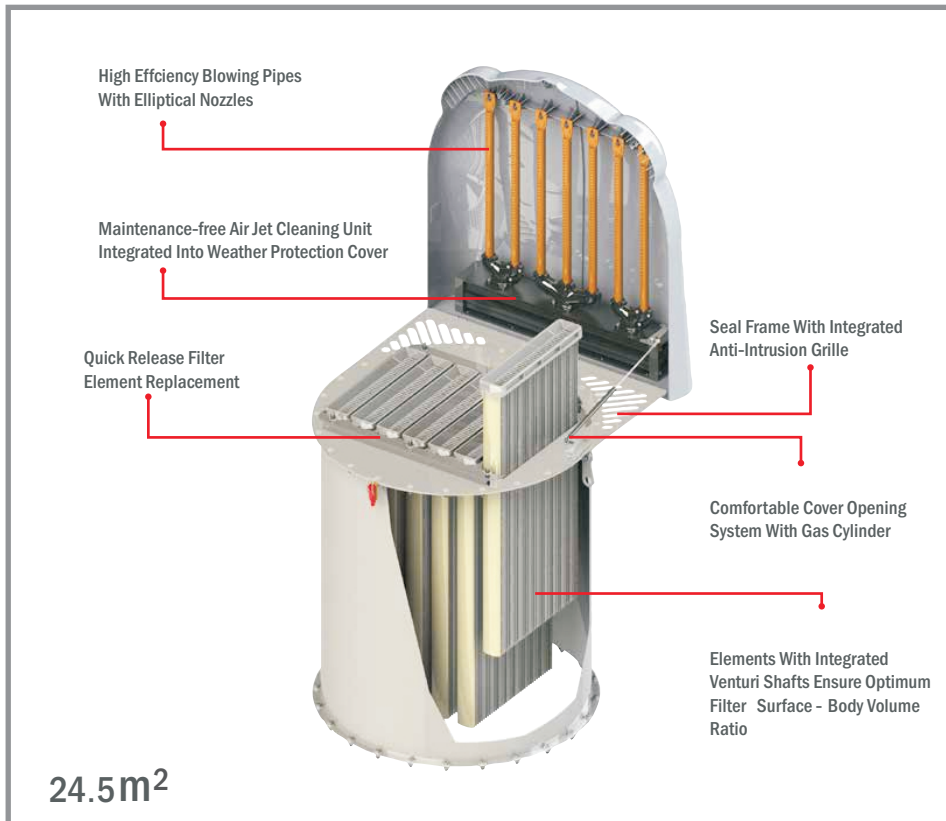

Overall Dimensions

CODE	BODY Ø mm [in]	FILTER SURFACE m ² [sq ft]	MAX. HEIGHT WHEN CLOSED mm [in]	MAX. HEIGHT WHEN OPEN mm [in]	WEIGHT kg [lb]
R 03	800 [31.5]	24.5 [150]	1,100 [43.3]	1,850 [72.8]	79 [174]

Dimensions in mm

BULK SOLIDS HANDLING EQUIPMENT

DESCRIPTION AND TECHNICAL CHARACTERISTICS

R03 DIMENSIONS

Overall Dimensions

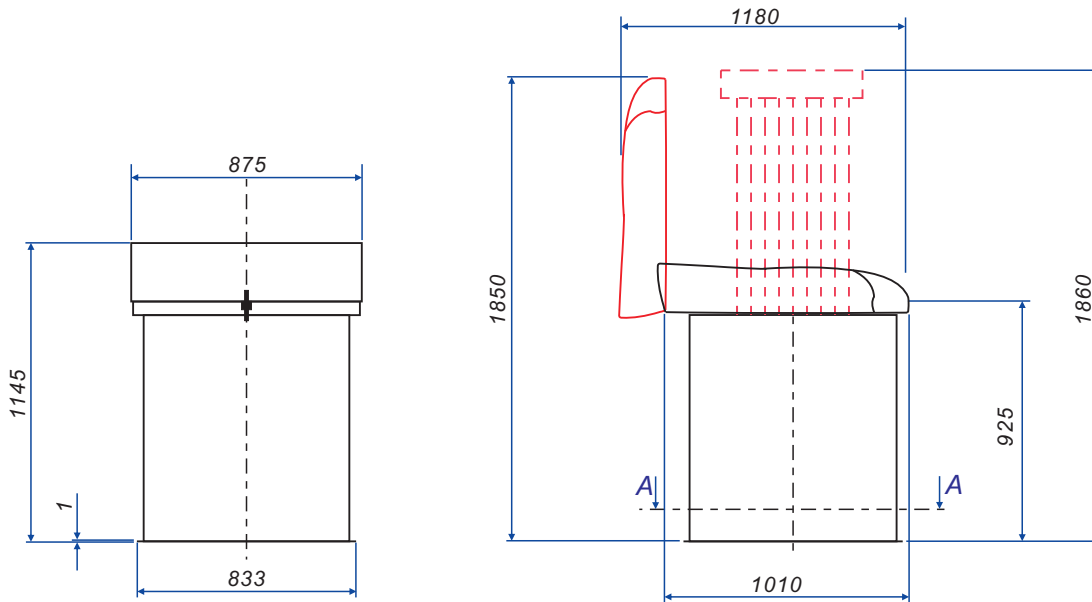

⑤ ONLY FOR MAINTENANCE

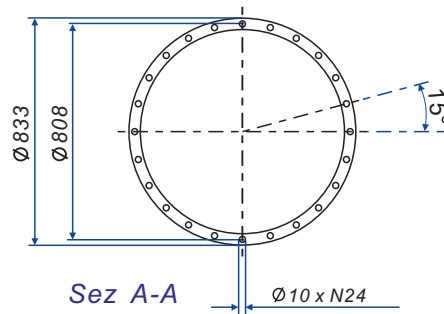

Dimensions in mm