

BULK SOLIDS HANDLING EQUIPMENT

SCREW CONVEYOR ACCESSORIES

Intermediate Hanger Bearing XL Series

XL series of intermediate shaft is screw feeder hanging essential connection is with self-lubricating liner hanger.



XLR

Performance & Technical Features - Benefits

- Material: Aluminum alloy
- Suitable for cement, lime and similar powders



Code

X | L | R | 0 | 4 | 0 | B | T

\varnothing Shaft 040= \varnothing 40mm	\varnothing Feeder 15= \varnothing 168 20= \varnothing 219 17= \varnothing 193 25= \varnothing 273 30= \varnothing 323
------------------------------------------------	---------------------------------------------------------------------------------------------------------------------------------------------------

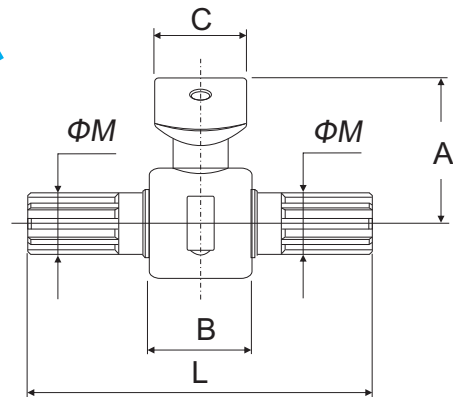
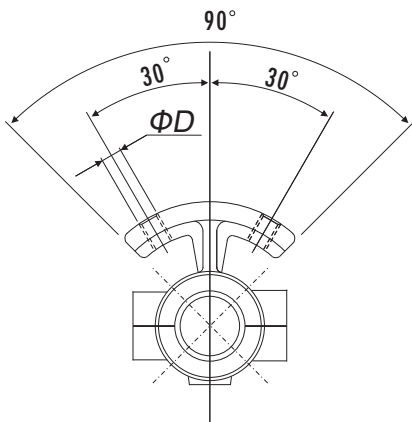

FOR: ES Screw conveyor

Code	Part #	\varnothing Shaft	\varnothing Feeder	A	B	C	D	M DIN 5482	L	Kg
ES 168	XLR040B015T	40	168	80	55	51	M14	40x36	245	3.5
ES 193	XLR040B017T	40	193	92.5	55	51	M14	40x36	245	3.5
ES 219	XLR040B020T	40	219	105.5	55	51	M14	40x36	245	3.9
ES 273	XLR040B025T	40	273	132.5	55	51	M14	40x36	245	4.5
ES 323	XLR040B030T	40	323	157.5	55	51	M14	40x36	245	5.0

Dimensions in mm