

BULK SOLIDS HANDLING EQUIPMENT

Electric Motovibrators

Electric vibrators MVE-series

MVE series single and three-phase standard vibration motor is a universal excitation source for all kinds of vibration machinery. This product can be widely used in mining, metallurgy, coal, electric power, construction, chemical, foundry, light industry food and other industries.

Electric Motovibrators

MVE

Performance characteristics

MVE series vibration motor technical parameters:

Rated voltage: 380V (three phase) 220V (single phase) (230/400V, 230/460V is also available)

DC voltage: 12V 24V 220V Rated frequency: 50HZ (60HZ is also available)

Insulation class: Main class H, wiring cavity F class Protection level: IP65

Working system: continuous (S1) excitation force adjustment range: 0—maximum

Excitation force: single phase 0-800kg three-phase 0---13000kg



Code

MVE	200	/3	M
Type	Force	Speed	Style
MVE	800mm	3: 3000RPM/Min 15: 1500RPM/Min	No: Standard M: Mini

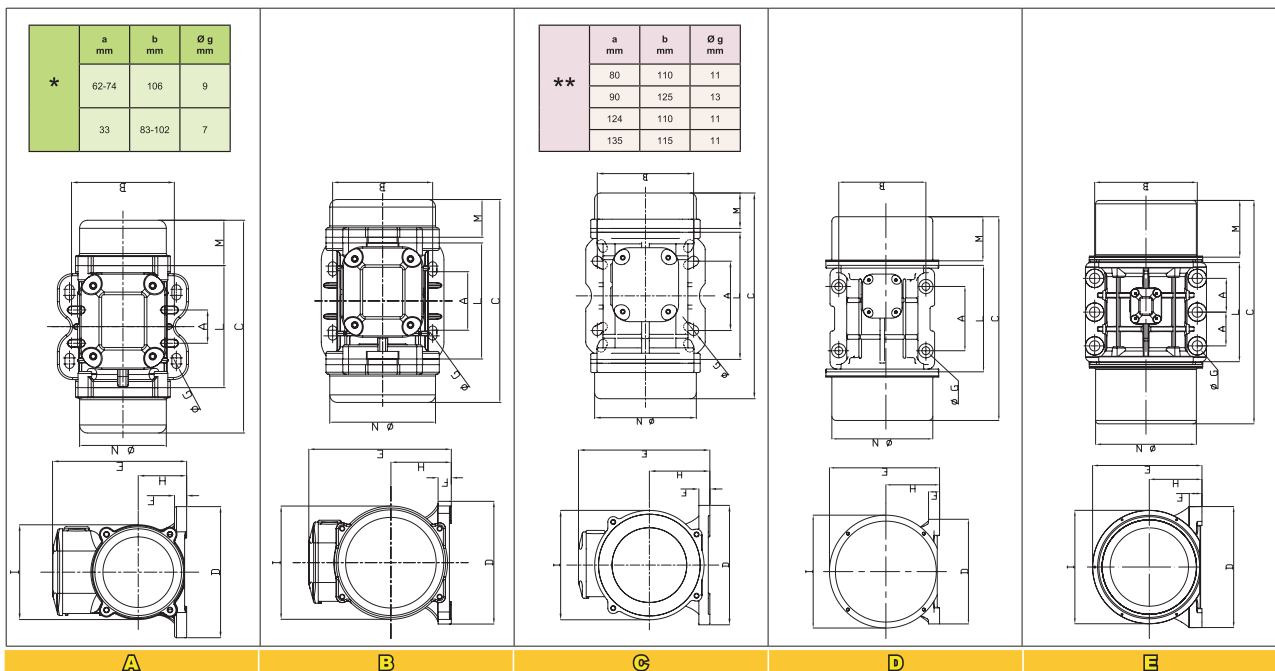

Dimensions in mm

BULK SOLIDS HANDLING EQUIPMENT

Electric Motovibrators 振动电机

MVE 振动电机 Electric vibrators MVE-series

MVE系列三相振动电机技术参数 (380V/50Hz) Technical data for MVE series three phase vibrators(380v/50Hz)
2极-3000转/分 (2Poles -3000rpm)

型号 TYPE	激振力 Force		激振功率 Power		效率 Efficiency		电流 Current		重量 Weight		机座号 SIZE	机座号 A	B	C	D	E	F	G	H	I	L	M	ΦN	电缆接头 Cable Gland	图号 Fig
	kg/f	kN	kw	%	A	kg																			
MVE60/3	71	0.7	0.03	46	0.16	4.2	SIZE10	62-74	106	211	130	136	12	9	48	94	121	45	86	M16X1.5	A				
MVE100/3	99	1	0.04	44	0.19	4.6	SIZE10	62-74	106	221	130	136	12	9	48	94	121	50	86	M16X1.5	A				
MVE200/3	198	2	0.09	60	0.35	6.8	SIZE20	62-74	106	231	131	159	15	9	64	121	123	54	112	M20X1.5	A				
MVE300/3	311	3	0.16	64	0.52	9.8	SIZE30	90	125	253	154	175	15	13	79	142	163	45	131	M20X1.5	B				
MVE400/3	400	4	0.20	74	0.58	10.3	SIZE30	90	125	273	154	175	15	13	79	142	163	55	131	M20X1.5	B				
MVE500/3	516	5	0.37	77	0.96	15.8	SIZE40	105	140	334	168	196	22	13	92	169	178	78	158	M20X1.5	B				
MVE700/3	750	7	0.45	77	1.25	16.5	SIZE40	105	140	334	168	196	22	13	92	169	178	78	158	M20X1.5	B				
MVE800/3	788	8	0.55	79	1.45	20.6	SIZE50	120	170	321	208	210	22	17	94	180	205	58	170	M20X1.5	B				
MVE1200/3	1018	10	0.75	82	1.85	21.6	SIZE50	120	170	321	208	210	22	17	94	180	205	58	170	M20X1.5	B				
MVE1300/3	1386	13	1.10	76	2.44	24.5	SIZE50	120	170	321	208	210	22	17	94	180	205	58	170	M20X1.5	B				
MVE1600/3	1571	16	1.25	81	2.94	51.6	SIZE60	140	190	416	229	247	30	17	120	247	220	80	222	M25X1.5	B				
MVE1800/3	1848	18	1.50	81	3.75	52.0	SIZE60	140	190	416	229	247	30	17	120	247	220	80	222	M25X1.5	B				
MVE2200/3	2033	20	2.00	83	4.07	52.8	SIZE60	140	190	416	229	247	30	17	120	247	220	80	222	M25X1.5	B				
MVE2300/3	2310	23	2.00	83	4.44	53.6	SIZE60	140	190	416	229	247	30	17	120	247	220	80	222	M25X1.5	B				
MVE3200/3	3250	32	2.20	76	5.30	96.9	SIZE75	155	255	538	302	318	35	25	147	295	273	115	264	M32X1.5	B				
MVE4000/3	4030	40	2.30	76	5.30	107	SIZE75	155	255	538	302	318	35	25	147	295	273	115	264	M32X1.5	B				
MVE5000/3	5070	50	3.50	83	7.22	111	SIZE75	155	255	588	302	318	35	25	147	295	273	140	264	M32X1.5	B				
MVE6500/3	6500	65	4.20	86	8.20	228	SIZE85	200	320	605	385	410	49	28	200	421	325	120	378	M32X1.5	B				
MVE9000/3	9030	90	7.20	72	10.3	240	SIZE85	200	320	605	385	410	49	28	200	421	325	120	378	M32X1.5	B				

MVE系列三相振动电机技术参数 (380V/50Hz) Technical data for MVE series three phase vibrators(380v/50Hz)
4极-1500转/分 (4Poles -1500rpm)

型号 TYPE	激振力 Force		激振功率 Power		效率 Efficiency		电流 Current		重量 Weight		机座号 SIZE	A	B	C	D	E	F	G	H	I	L	M	ΦN	电缆接头 Cable Gland	图号 Fig
	kg/f	kN	kw	%	A	kg																			
MVE40/15	32	0.3	0.03	33	0.26	4.6	SIZE10	62-74	106	221	130	136	12	9	48	94	121	50	86	M16X1.5	A				
MVE90/15	90	0.9	0.04	36	0.31	7.4	SIZE20	62-74	106	231	131	159	15	9	64	121	123	54	112	M20X1.5	A				
MVE200/15	183	2	0.06	50	0.49	11.8	SIZE30	90	125	273	154	175	15	13	79	142	163	55	131	M20X1.5	B				
MVE250/15	257	2.5	0.07	54	0.54	13.2	SIZE30	90	125	303	154	175	15	13	79	142	163	70	131	M20X1.5	B				
MVE300/15	305	3	0.08	57	0.62	16.5	SIZE30	90	125	303	154	175	15	13	79	142	163	70	131	M20X1.5	B				
MVE400/15	388	4	0.15	60	0.84	19.5	SIZE40	105	140	334	168	196	22	13	92	169	178	78	158	M20X1.5	B				
MVE500/15	518	5	0.25	68	1.06	21.0	SIZE40	105	140	334	168	196	22	13	92	169	178	78	158	M20X1.5	B				
MVE700/15	693	7	0.37	77	1.32	27.4	SIZE50	120	170	391	208	210	22	17	94	180	205	93	170	M20X1.5	B				
MVE800/15	807	8	0.40	73	1.36	28.3	SIZE50	120	170	391	208	210	22	17	94	180	205	93	170	M20X1.5	B				
MVE1100/15	1045	11	0.40	73	1.40	35.8	SIZE50	120	170	451	208	210	22	17	94	180	205	123	170	M20X1.5	B				
MVE1400/15	1406	14	0.45	75	1.78	59.8	SIZE60	140	190	448	229	247	30	17	120	247	220	96	222	M25X1.5	B				
MVE1700/15	1757	17	0.75	68	2.09	61.8	SIZE60	140	190	448	229	247	30	17	120	247	220	96	222	M25X1.5	B				
MVE2400/15	2420	24	1.00	71	3.20	68.0	SIZE60	140	190	514	229	247	30	17	120	247	220	129	222	M25X1.5	B				
MVE2500/15	2500	25	1.20	75	3.40	90.0	SIZE70	155	225	522	272	284	40	22	141	267	250	123	235	M25X1.5	B				
MVE3000/15	3065	30	1.50	79	3.68	97.5	SIZE70	155	225	522	272	284	40	22	141	267	250	123	235	M25X1.5	B				
MVE3800/15	3830	38	1.72	78	4.15	130.4	SIZE75	155	255	588	302	318	35	23.5	147	295	273	140	264	M32X1.5	B				
MVE4300/15	4312	43	1.94	78	4.50	134.4	SIZE75	155	255	588	302	318	35	23.5	147	295	273	140	264	M32X1.5	B				
MVE5500/15	5576	55	2.20	73	6.50	192.2	SIZE80	180	280	603	332	360	37	26	168	345	304	130	310	M32X1.5	B				
MVE7200/15	7188	72	3.00	75	9.60	253.0	SIZE85	200	320	605	385	410	49	28	200	422	325	120	378	M32X1.5	B				

MVE-M系列二相振动电机技术参数 (220V/50Hz) Technical data for MVE-M series single phase vibrators(220v/50Hz)
2极-3000转/分 (2Poles -3000rpm)

型号 TYPE	激振力 Force		输入功率 Power		电容 Capacitor		电流 Current		重量 Weight		机座号 SIZE	机座号 A	B	C	D	E	F	G	H	I	L	M	ΦN	电缆接头 Cable Gland	图号 Fig
	kg/f	kN	kw	UF	A	kg																			
MVE60/3M	66	0.7	0.08	4	0.43	4.5	SIZE10	62-74	106	211	130	136	12	9	48	94	121	45	86	M16X1.5	A				
MVE100/3M	99	1	0.10	4	0.54	5.1	SIZE10	62-74	106	221	130	136	12	9	48	94	121	50	86	M16X1.5	A				
MVE200/3M	197	2	0.13	5	0.71	6.8	SIZE20	62-74	106	231	131	159	15	9	64	121	123	54	112	M20X1.5	A				
MVE300/3M	311	3	0.29	12	1.58	10.0	SIZE30	90	125	253	154	175	15	13	79	142	163	45	131	M20X1.5	B				
MVE400/3M	400	4	0.31	12	1.68	10.8	SIZE30	90	125	273	154	175	15	13	79	142	163	55	131	M20X1.5	B				

Dimensions in mm